

From a Culture of Violence to a Culture of Peace: Transforming the Human Spirit (36 Panels)

This exhibit consists of six 6-panel self-standing units and is shipped in three containers.

Layout:

The complete exhibit needs approximately 1,200 square feet of floor space. It does not require electric service since it is illuminated by the general room lighting. The exhibit is designed to be flexible in its configuration. If space is limited, it can be displayed as a one-sided unit with fewer graphics. Please refer to the attached **Exhibit layout** for placement of the graphics on the panels.

Assembly:

The exhibit requires no special tools for assembly. The steel frame snaps together and the fabric graphics are attached to the frames with wings nuts, included with the exhibit, as shown in the attached diagram. The exhibit is 7 feet tall and could require a ladder for assembly. It will take four people approximately one hour to completely assemble the full exhibit.

Suggested assembly order for the 6 sided units:

1. Assemble **Vertical Joints** with male connectors on the ground (#1 and #2)
2. Assemble **End Pieces**
3. Lay assembled **Vertical Joint** on the ground and connect four **Horizontals**.
4. Attach the **End Pieces** to the **Horizontals**
5. Carefully tilt the frame to an upright position
6. Attach the remaining two **Horizontals** followed by their **End Piece**
7. Attach the **Graphics**

Packing and shipping:

Each exhibit part is packed in a canvas bag, this helps protect the surface of the steel from being scratched and dented. The exhibit is shipped in three plastic containers (17" X 19" X 53" weighting approximately 130 pounds each). Please use *tie wraps* to secure the two locks on the container when packing for return shipping. FedEx labels are included and should be wrapped around the handle of the container. Labels on the side of the container tend to fall off and containers could be lost during shipping. Each container should be insured (Declared Value) for \$1,300.00 for a total of \$4,000.00 for the entire shipment.

Inventory:

Graphics

36 color panels in canvas bags

Frames

Six steel frame units in canvas bags

6 sided frames

| | |
|--------|---|
| 1 each | Vertical Joints M&F (2 pieces) (1 shipping bag) |
| 6 each | 50 inch Horizontals (6 pieces) (2 shipping bags) |
| 3 each | End Pieces M&F (6 pieces) (2 shipping bags) |
| 6 each | Graphics (6 pieces) (1 shipping bags) |

Hardware

One-Hundred (100) #10 (3 /16th) washers
One-Hundred (100) 10-24 wing nuts
One-Hundred (100) 24 x2 phillips round head screws

Extra Supplies

10 - frame pin clips, plastic tie wraps to secure each clasp on shipping cases and Federal Express Shipping Tags

From a Culture of Violence to a Culture of Peace: Transforming the Human Spirit
Exhibit outline, August 7, 2007, USA / Canada Version

Section 1

ENSURING HUMAN SECURITY

- Panel 1-2 Title: ...Transforming the Human Spirit
- Panel 3-4 What Does Security Mean to Me?
- Panel 5-6 Freedom from Fear and Freedom from Want
- Panel 7-8 What Can we do to Promote Human Security

Section 2

ARMS-BASED SECURITY VS HUMAN SECURITY

- Panel 9-10 Wars Begin in the Minds of Men
- Panel 11-12 Arms-Based Security: A Precarious Logic
- Panel 13-14 The Continuing Threat
- Panel 15-16 What Happens When a Nuclear Bomb Explodes
- Panel 17-18 At the Crossroads

Section 3

CHANGING OUR WORLDVIEW

- Panel 19-20 Transforming the Human Spirit
- Panel 21 Interconnections
- Panel 22 Dialogue
- Panel 23 Education
- Panel 24 Courage
- Panel 25 Engagement
- Panel 26 Hope

Section 4

GLOBAL EFFORTS FOR PEACE

- Panel 27-28 From a Culture of Violence to a Culture of Peace
- Panel 29-30 **PEOPLE ACTING FOR PEACE**
Efforts to Control and Eliminate Nuclear Weapons
- Panel 31-32 **INTERGOVERNMENTAL EFFORTS FOR PEACE**
Organizational Efforts to Eliminate Nuclear Weapons
- Panel 33 Peace Heroes (37)
W. Maathai, A. Esquivel, J. Rotblat
- Panel 34 Peace Heroes (38)
B. Williams, L. Pauling, N. Mandela,
- Panel 35 Competition Between Despair and Hope
SGI Activities for Peace and Nuclear Abolition
- Panel 36 Declaration Calling for the Abolition of Nuclear Weapons

From a Culture of Violence to a Culture of Peace: Transforming the Human Spirit

Exhibit layout - USA/Canada Version
top view

Unit 1

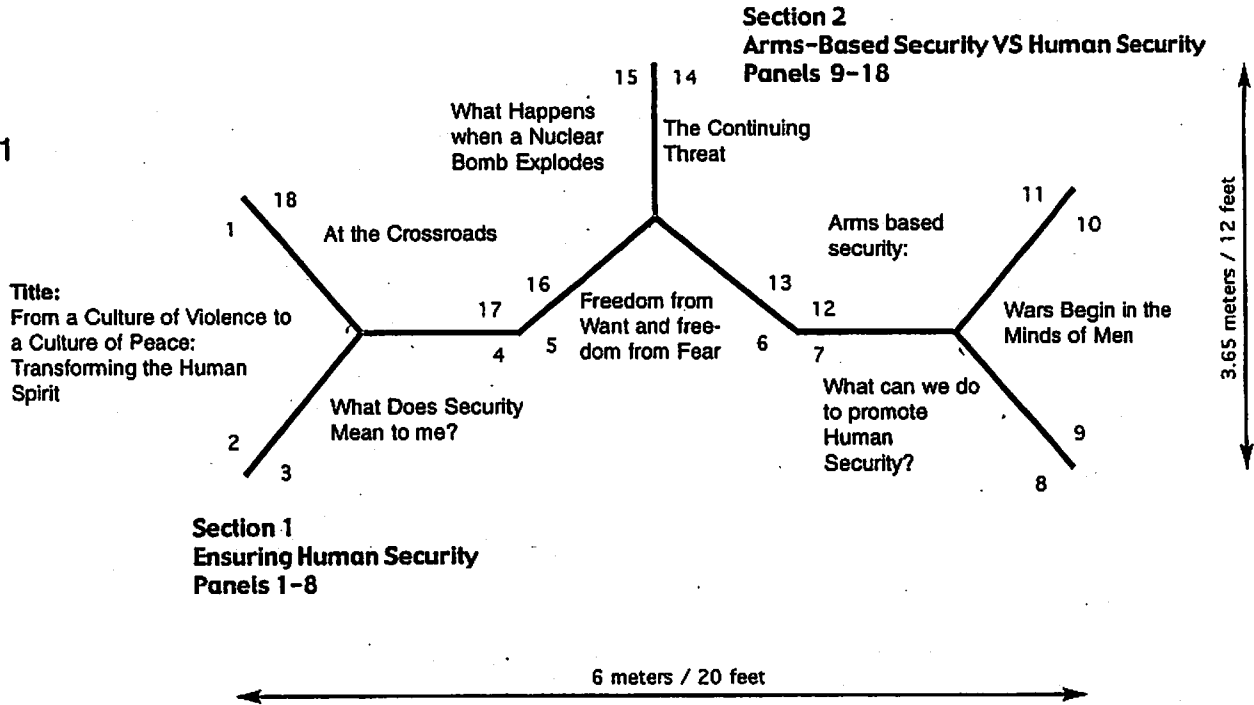

Unit 2

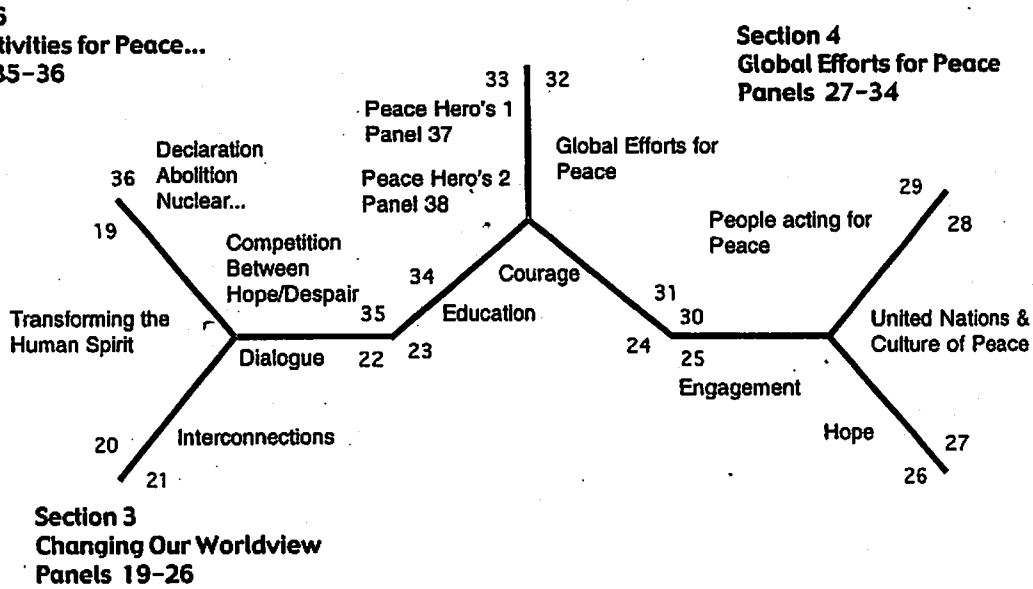

Alternative Panels

- Peace Hero's 3, Panel 39
- World Court Project, Panel 33
- Nuclear Free Zones, Panel 34

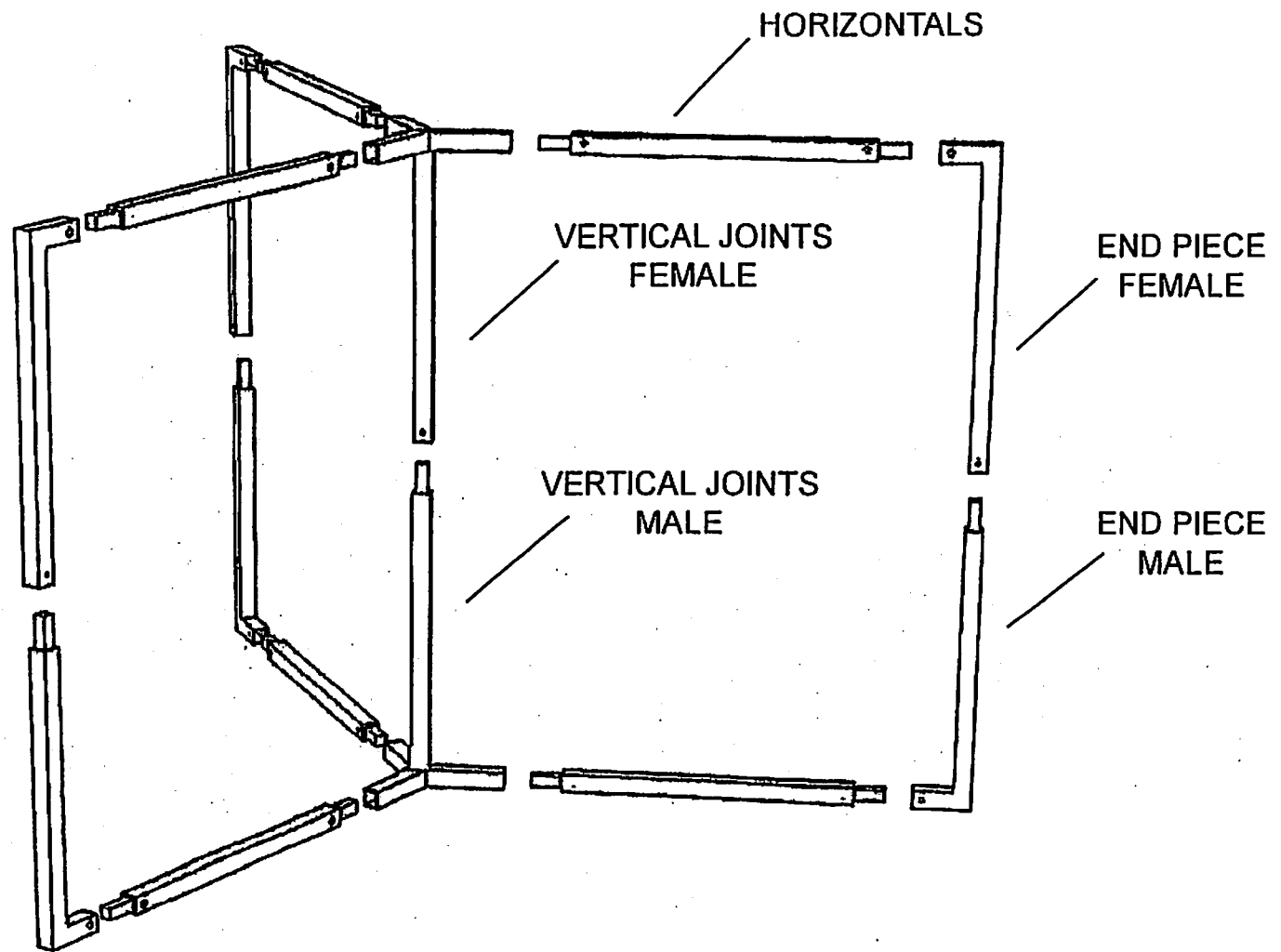

END PIECES
MALE & FEMALE

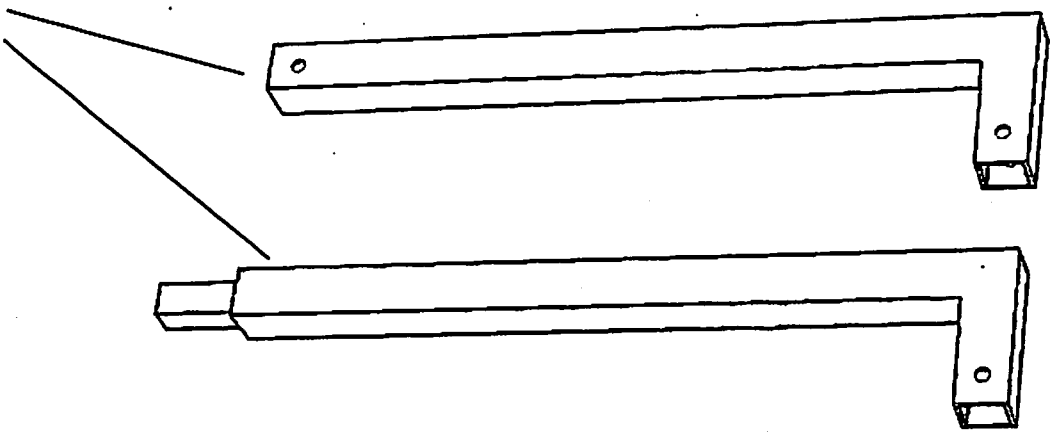

HORIZONTALS

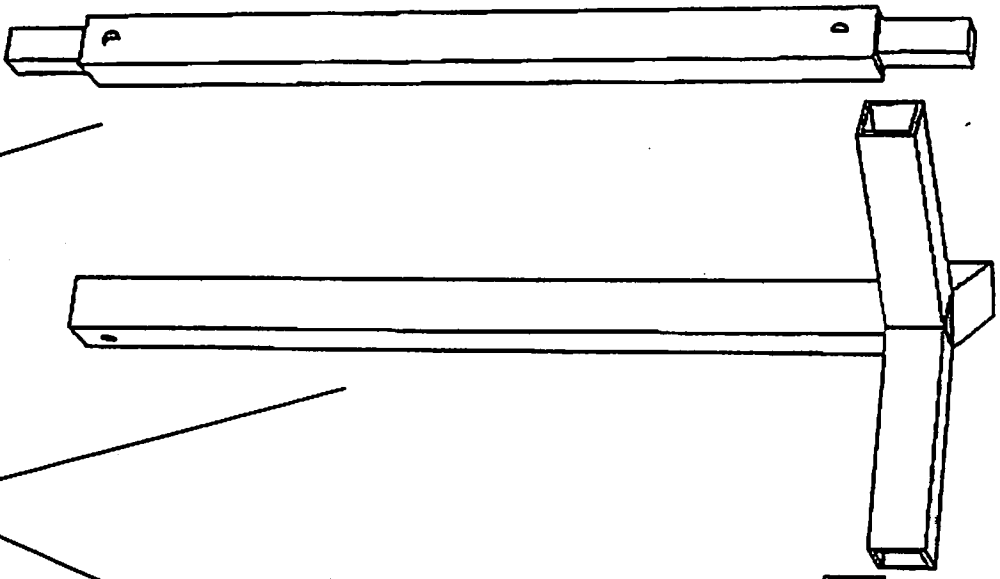

VERTICAL JOINTS
MALE & FEMALE

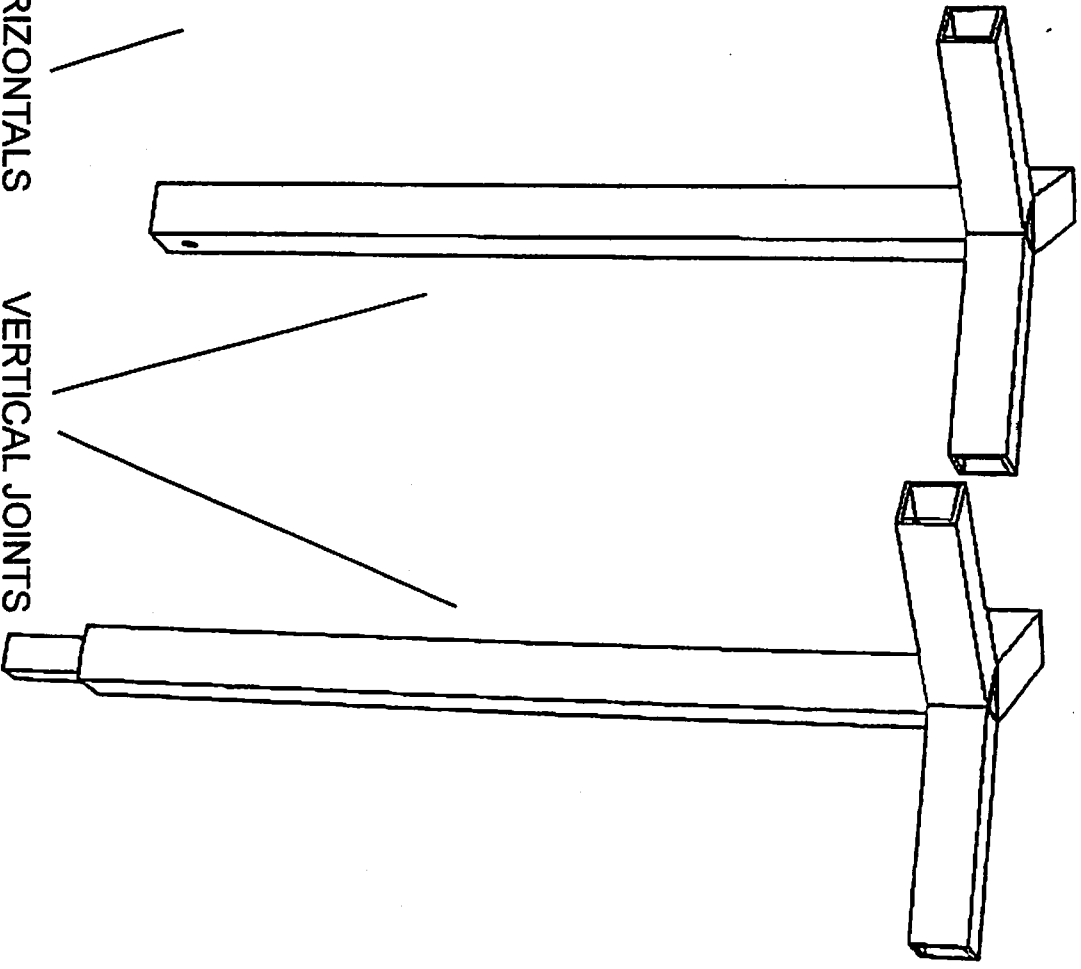

All pieces are made of 3/4" square tubing. Pins are 1/2" square tubing.

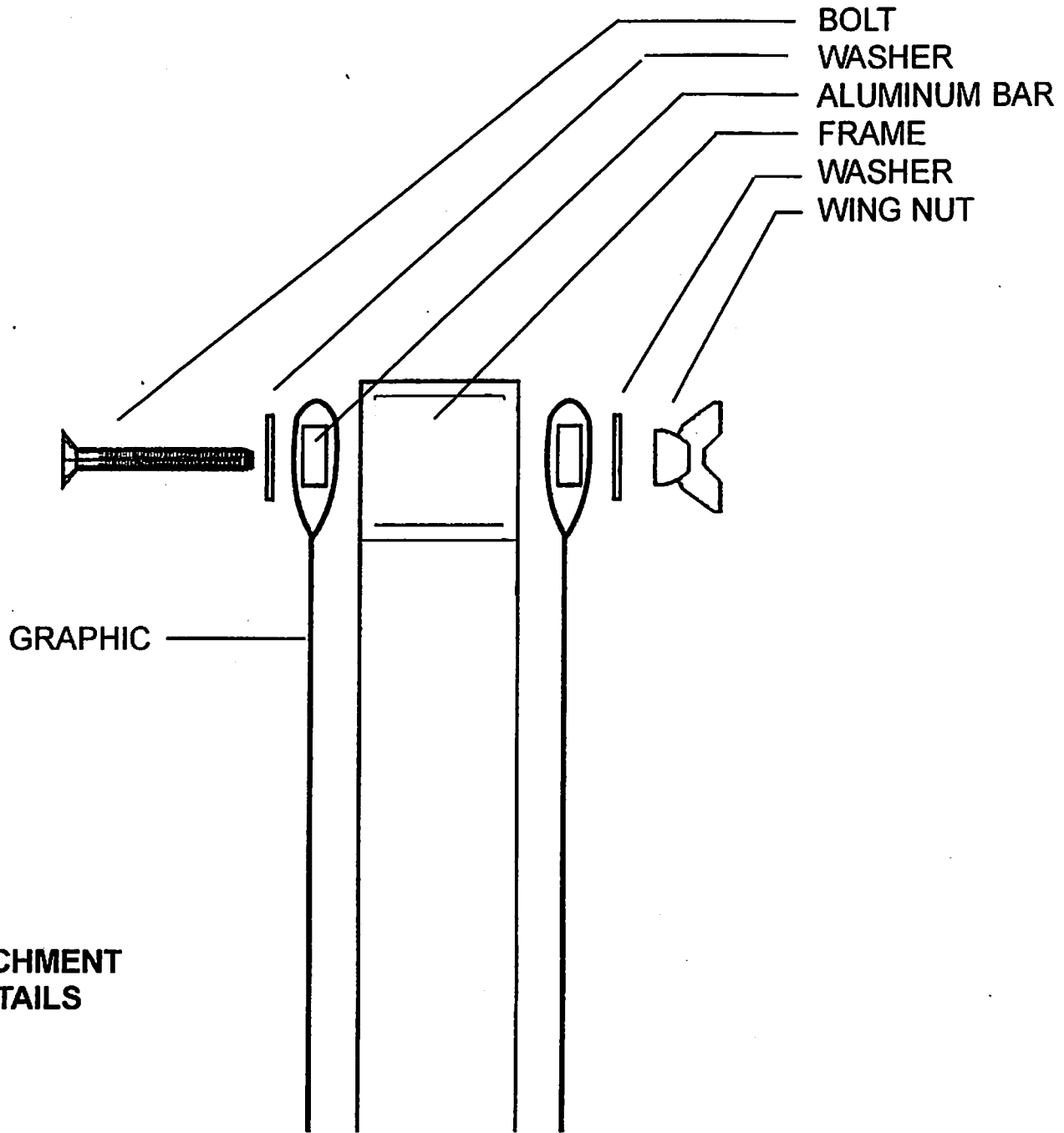

ATTACHMENT
DETAILS

GRAPHIC